

1. Open Chords

KEY: ● or ○ = Root Note ○ = Play this string X = Don't play this string

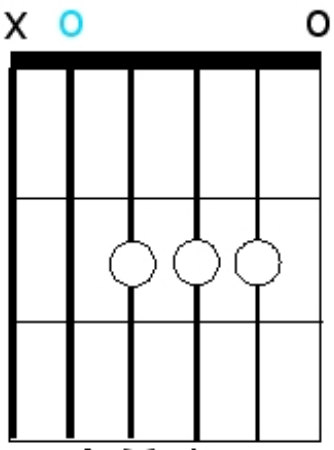

A Major

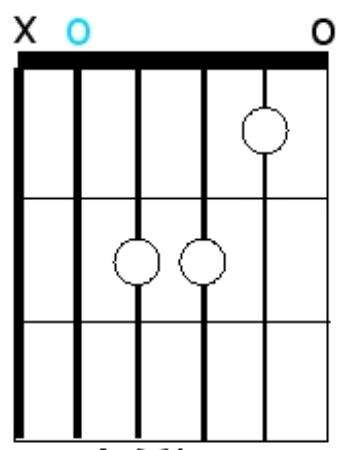

A Minor

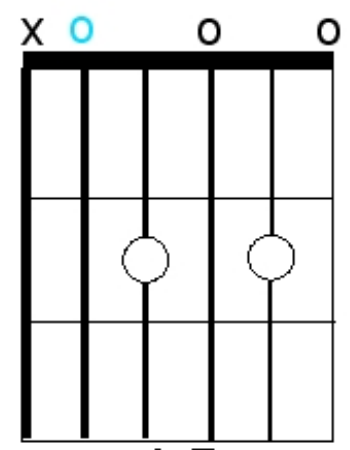

A 7

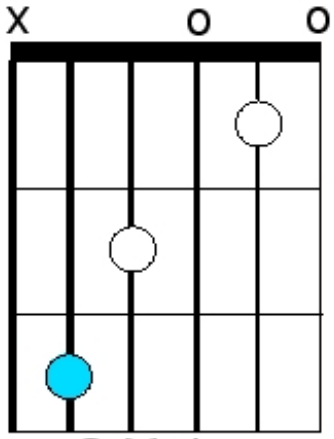

C Major

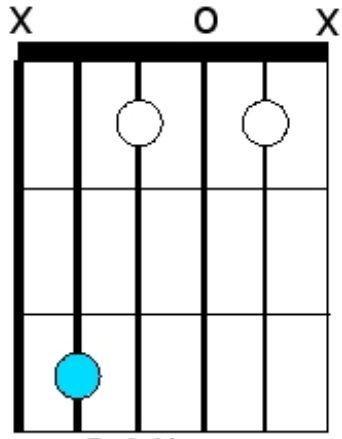

C Minor

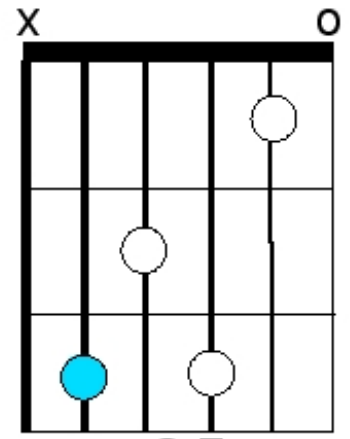

C 7

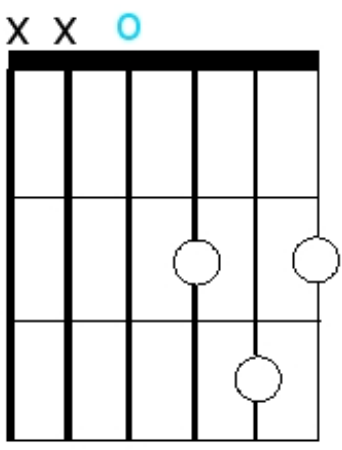

D Major

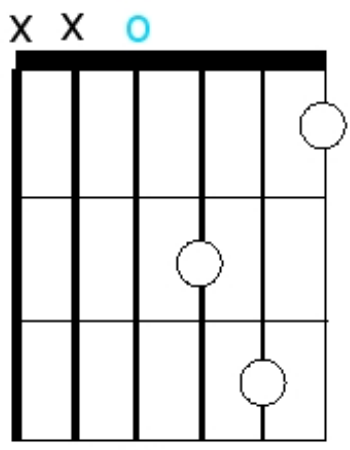

D Minor

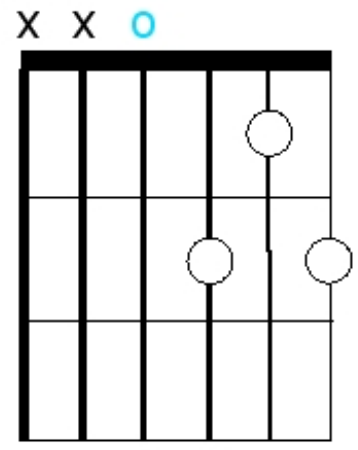

D 7

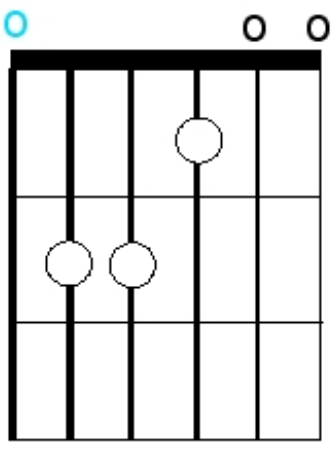

E Major

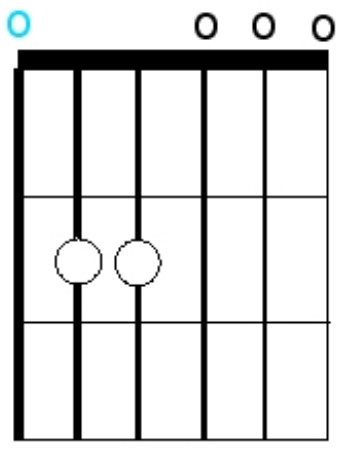

E Minor

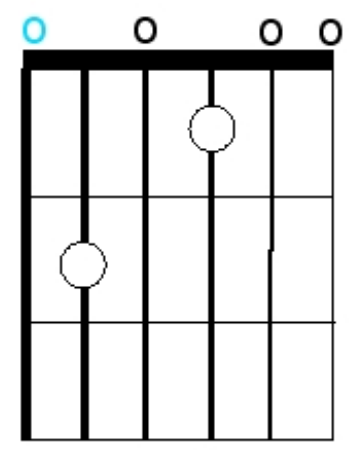

E 7

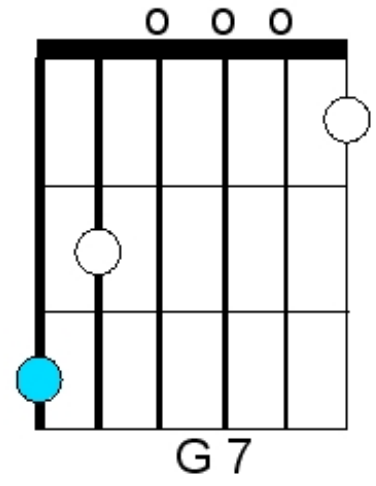
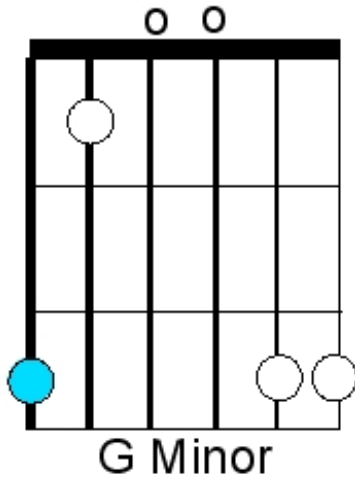
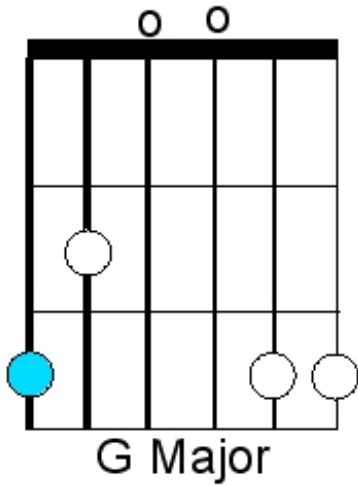
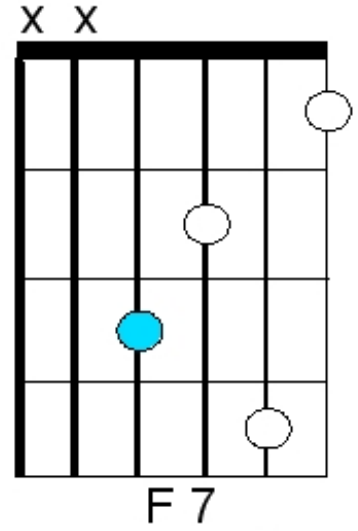
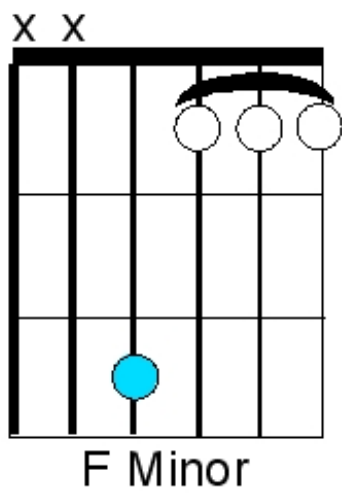
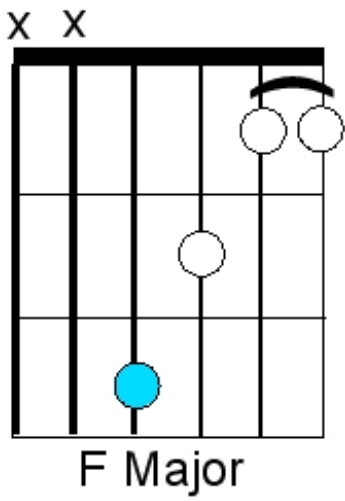

2. Major Moveable Chords

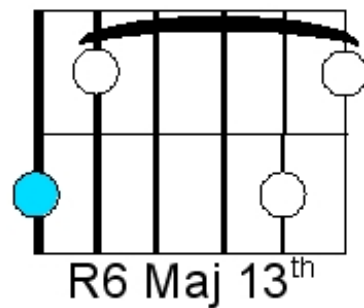
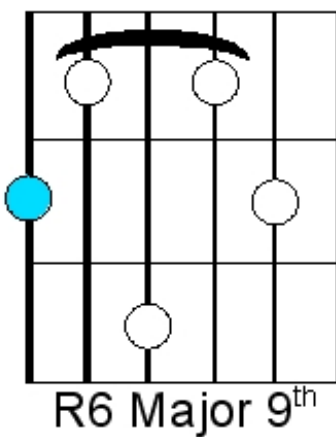
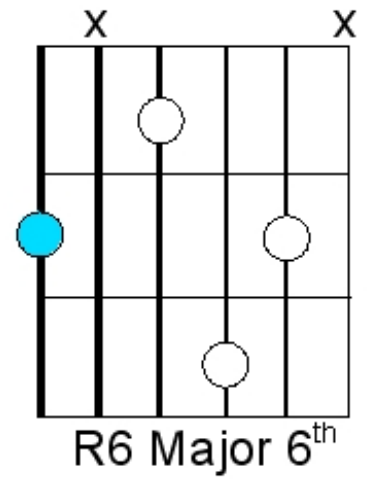
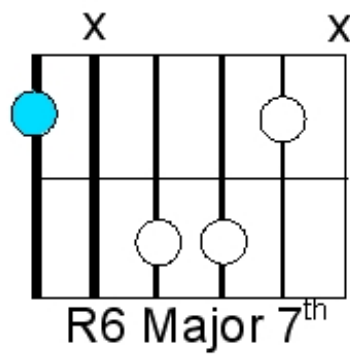
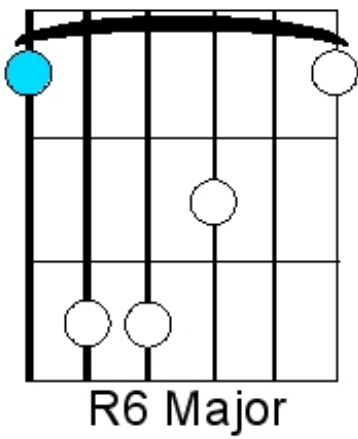

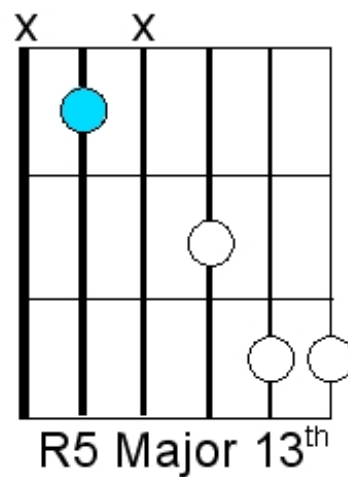
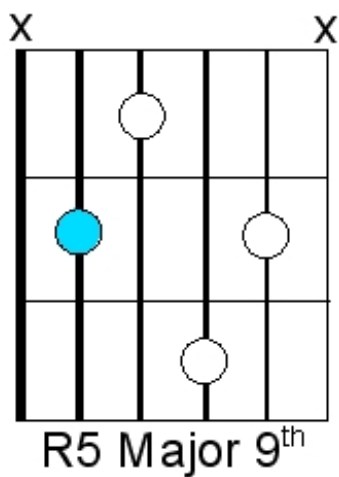
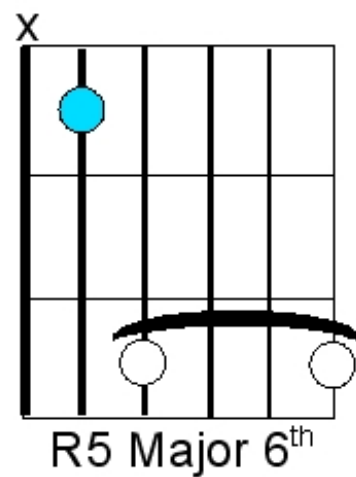
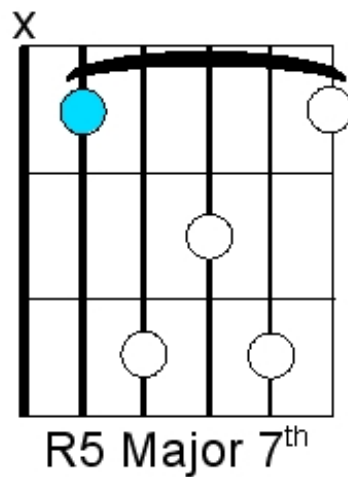
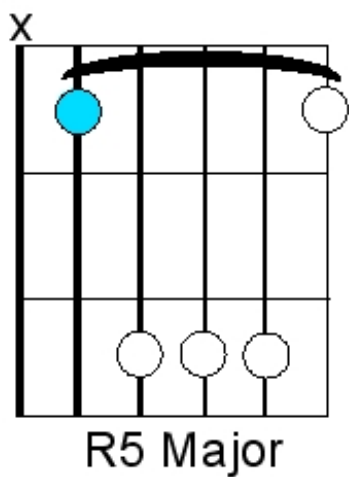

3. Minor Moveable Chords

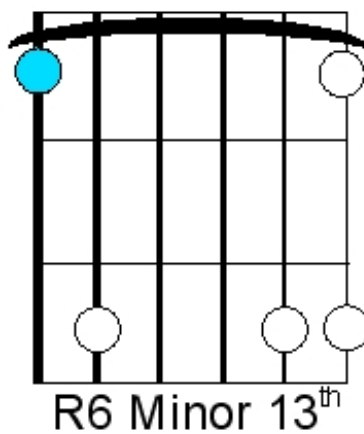
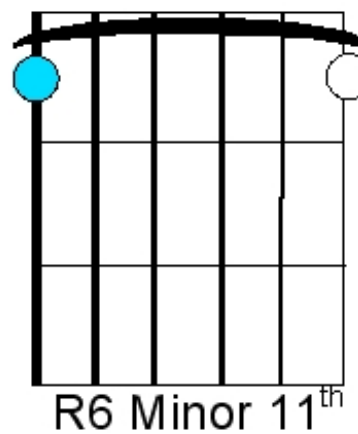
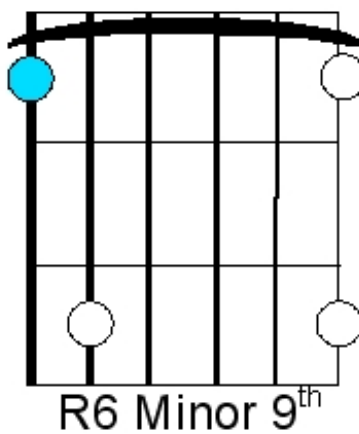
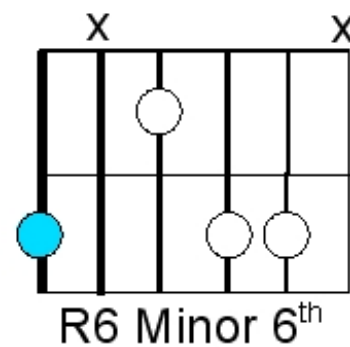
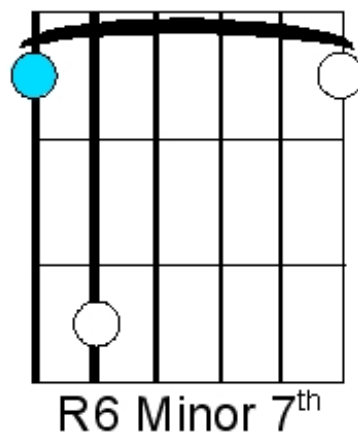
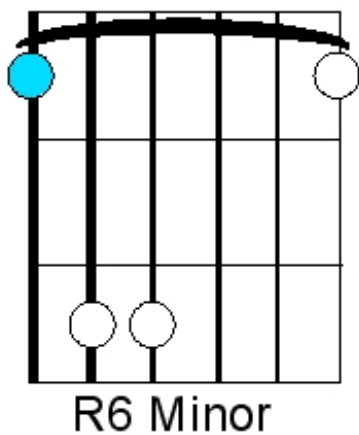

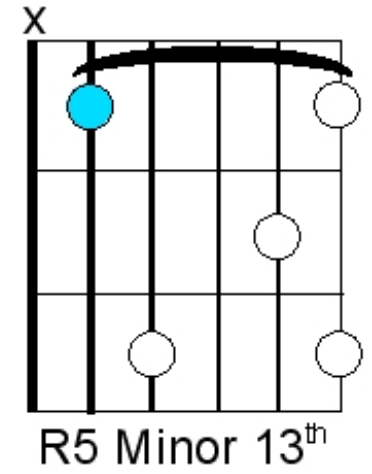
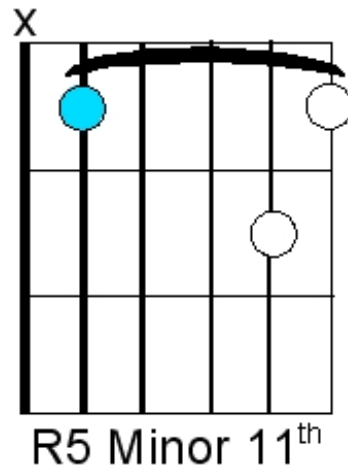
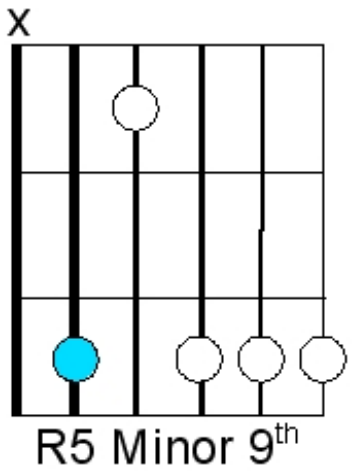
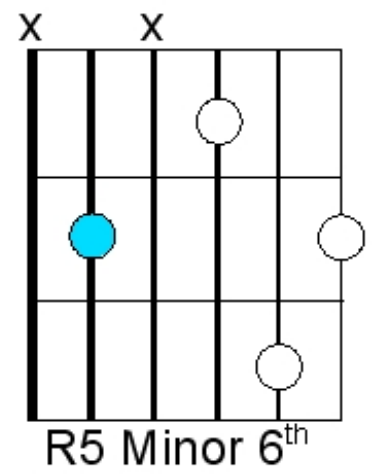
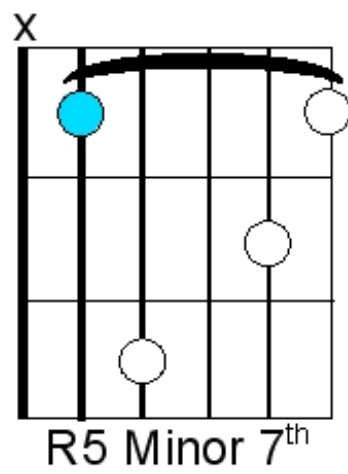
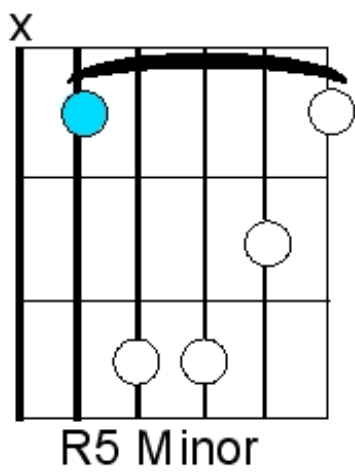

4. Dominant Moveable Chords

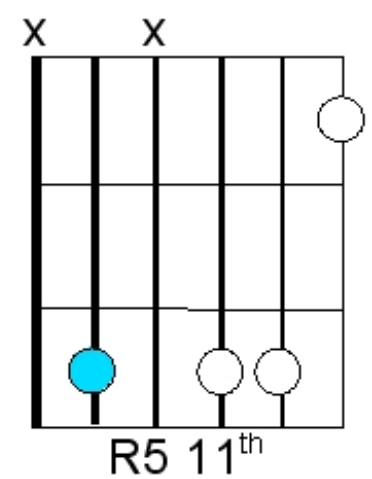
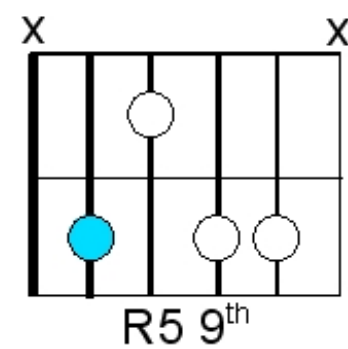
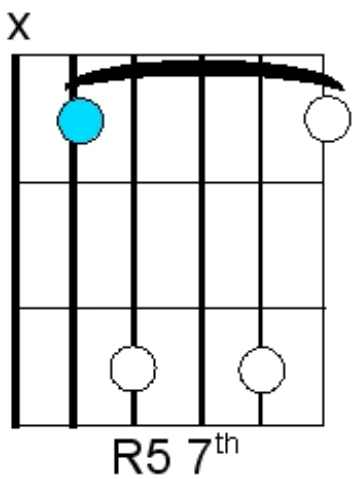
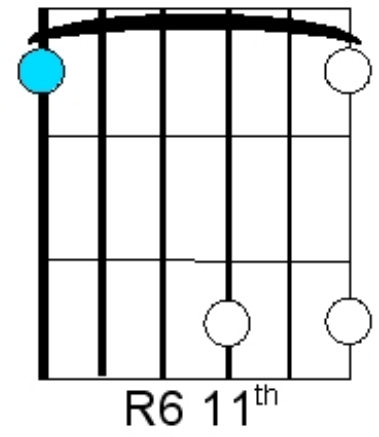
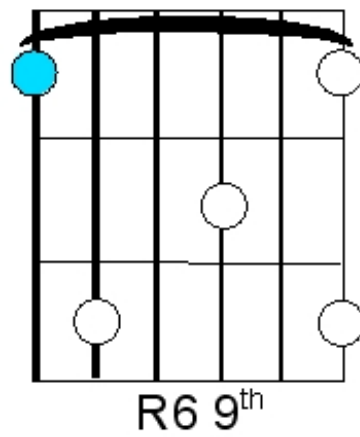
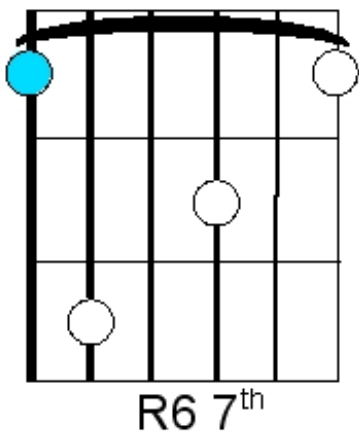

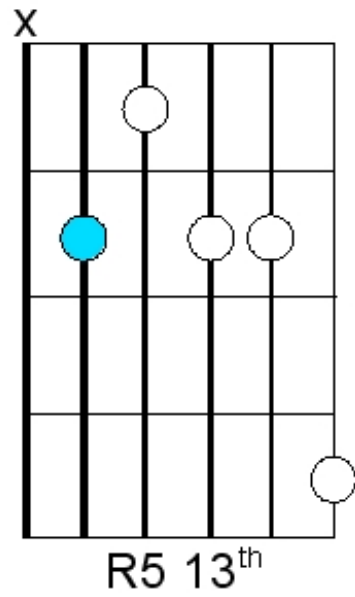
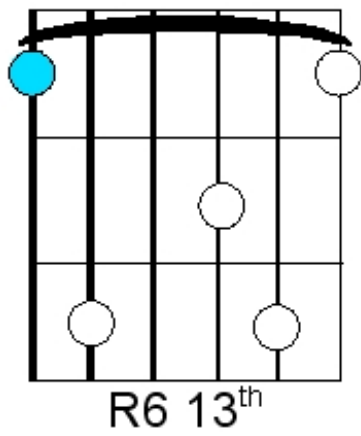

5. Suspended Moveable Chords

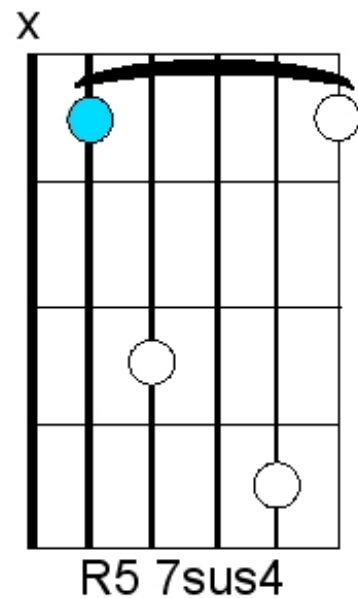
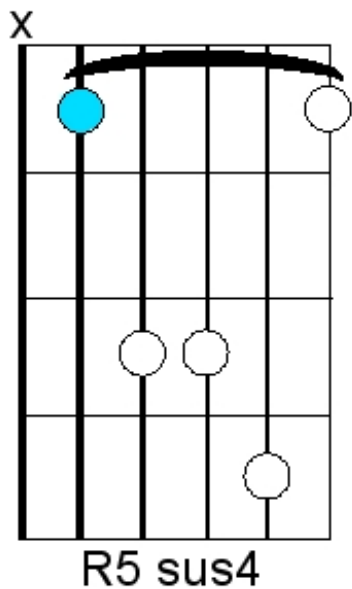
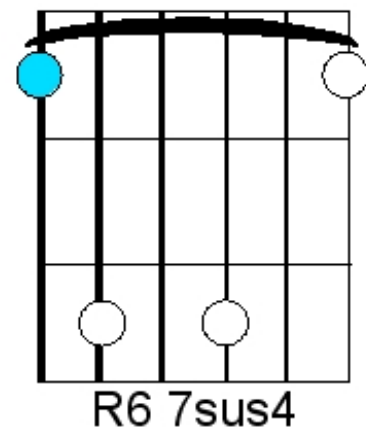
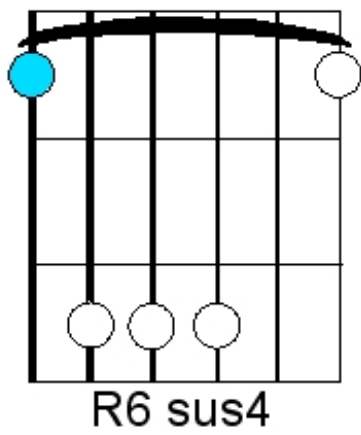

6. Diminished Moveable Chords

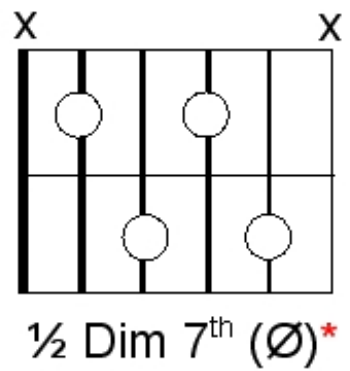
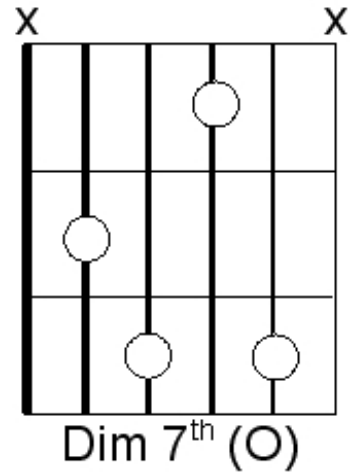
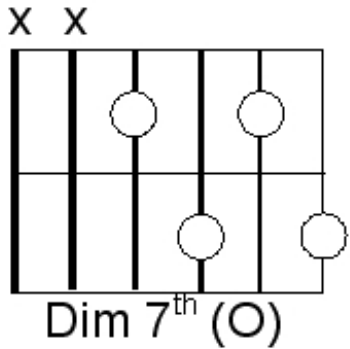

*Also known as min7b5

7. Augmented Moveable Chords

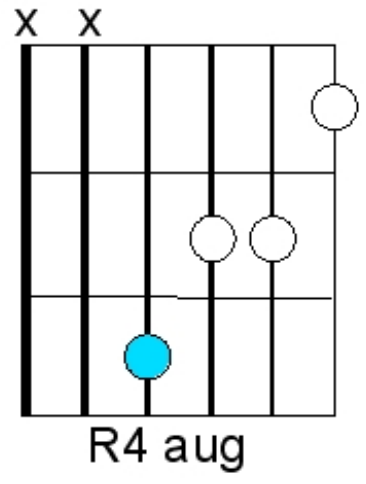
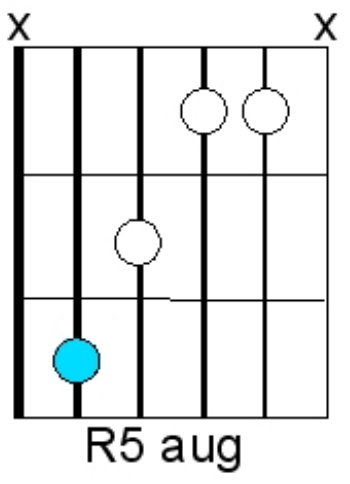
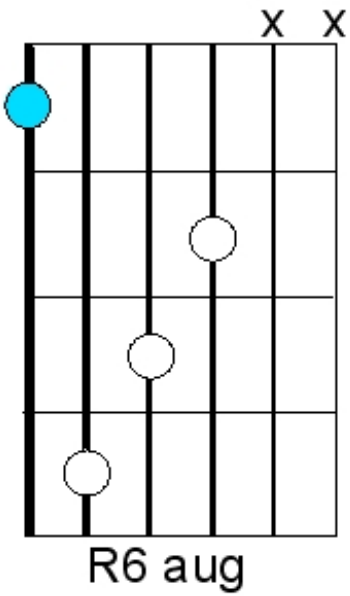

N.B. Can also be written as e.g. R6+

8. Powerchords*

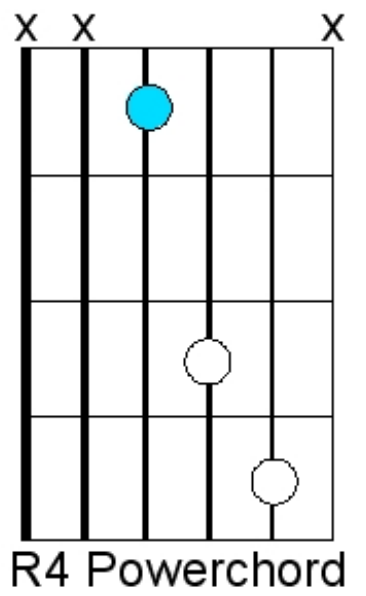
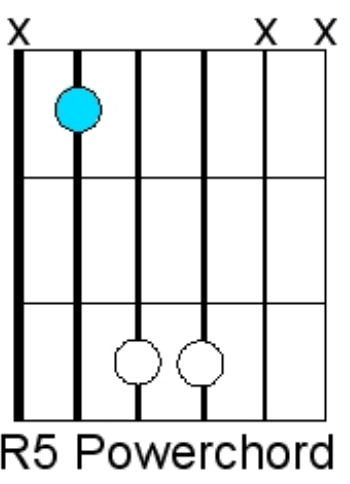
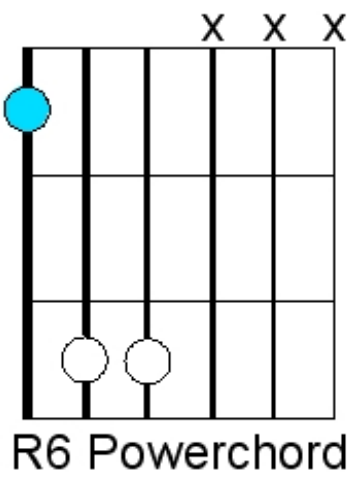

*Also known as '5' chords eg. E5, C5 etc.